



Features

- 2830mm x 1830mm X 1980mm body
- Twin braked axles 3000kg maximum GLW
- 83mm insulated panels
- Insulated floor with non-slip surface
- Slide out step
- Pair of rear stabilising legs
- Govi Artic 2000P chiller with 16amp skt
- +10 to -20° temperature range
- 10.34 cu mt of storage space
- Pressure relief valve

TOW MASTER

3mt Fridge Trailer

HF030





Optional Extras

- Polypropylene shelving
- Wheel clamp

An Icebox Fridge trailer is ideal if you have a need for temporary, emergency or portable cold storage solutions. With a temperature range of +10 to -20° Icebox fridge trailers can be used as fridge or freezer.

All trailers have an automatic interior light and the chiller automatically switches itself on or off when the door is opened or closed.

There is a slide out step below the access door and a pair of rear drop legs to stabilise the trailer on site.

**TOW
MASTER**

3mt Fridge Trailer
HF030

3mt Fridge Trailer
HF030

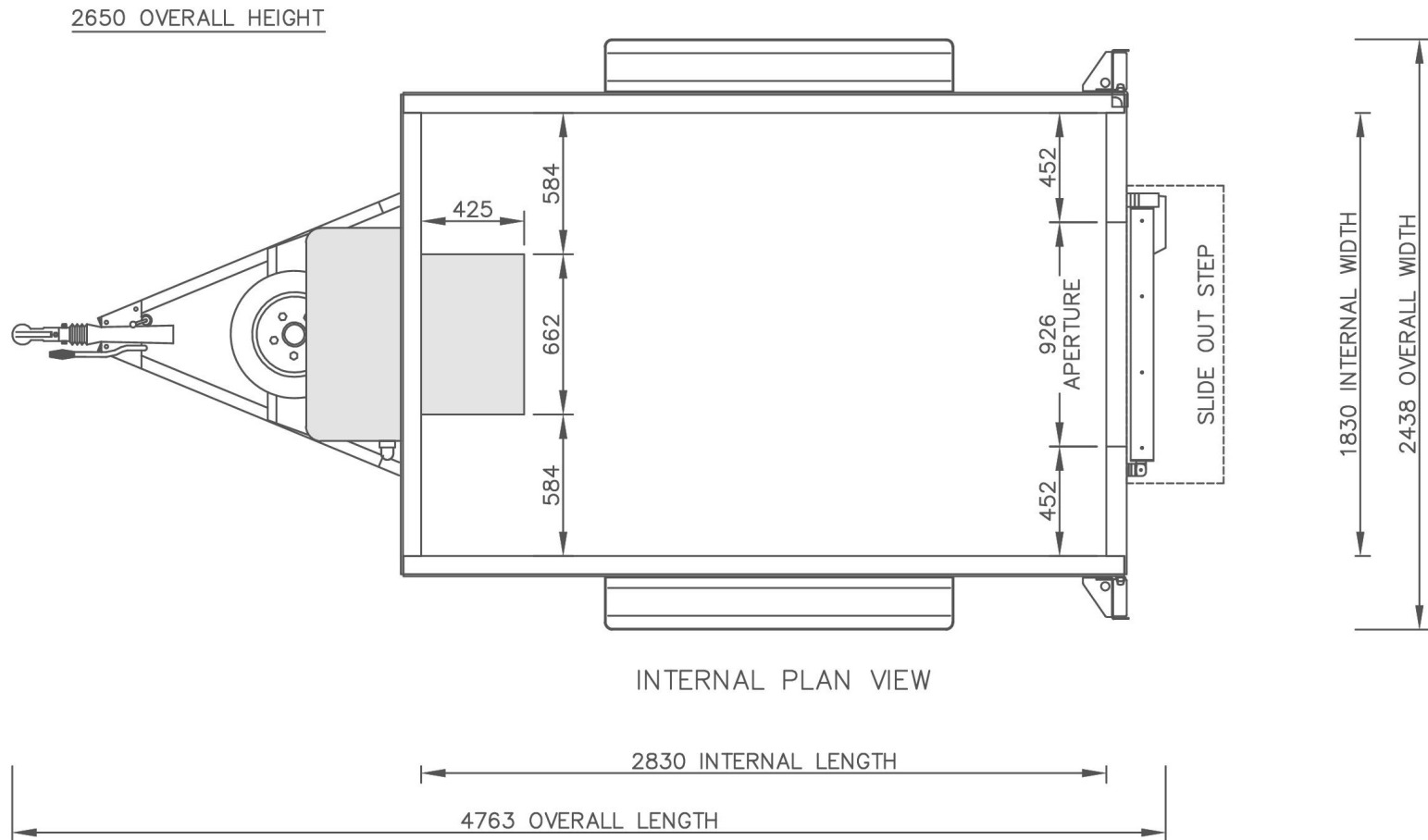

Plan view

3mt Fridge Trailer
HF030

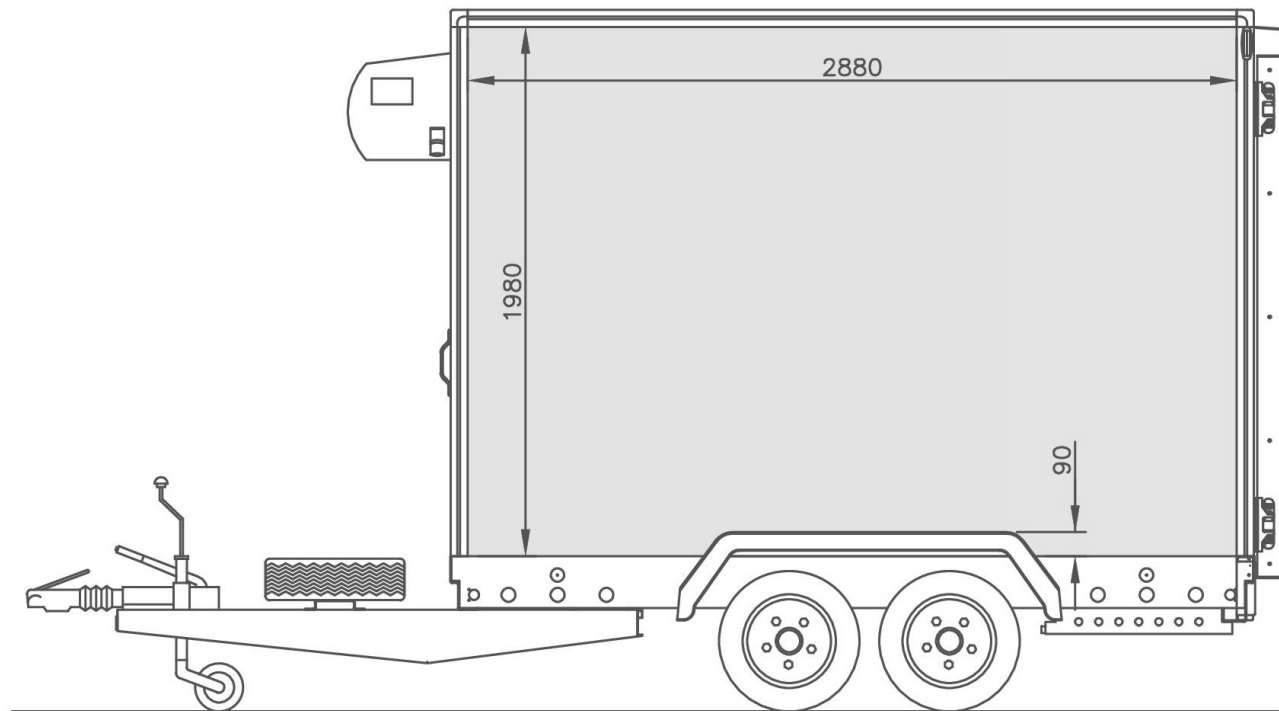

NEAR SIDE VIEW

Panel dimensions near side / off side

3mt Fridge Trailer
HF030

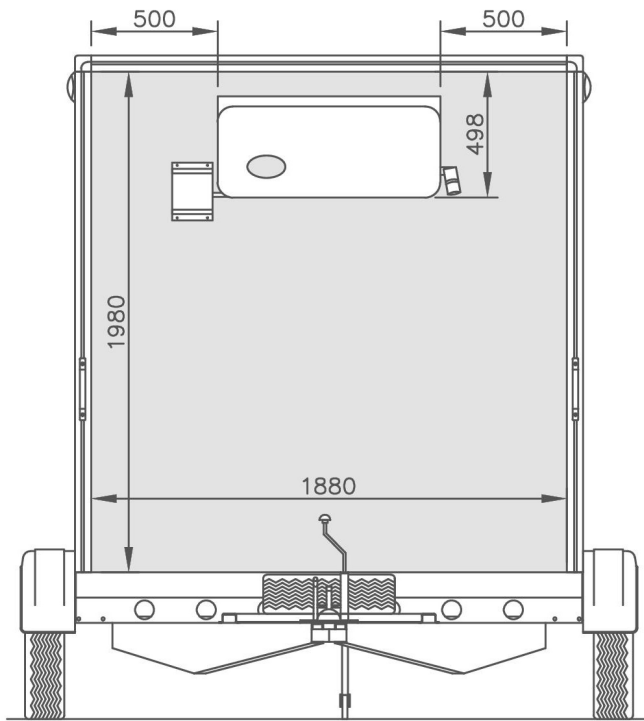

FRONT VIEW

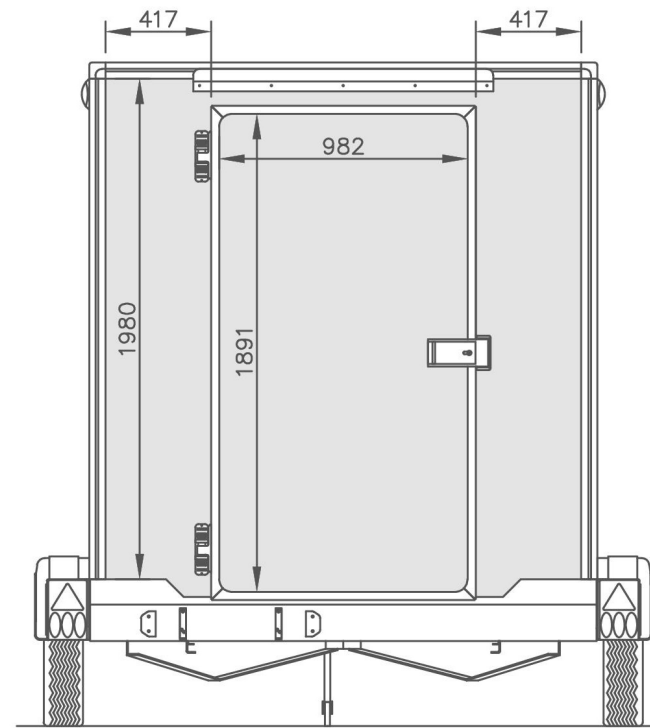

REAR VIEW

Panel dimensions front and rear

3mt Fridge Trailer
HF030

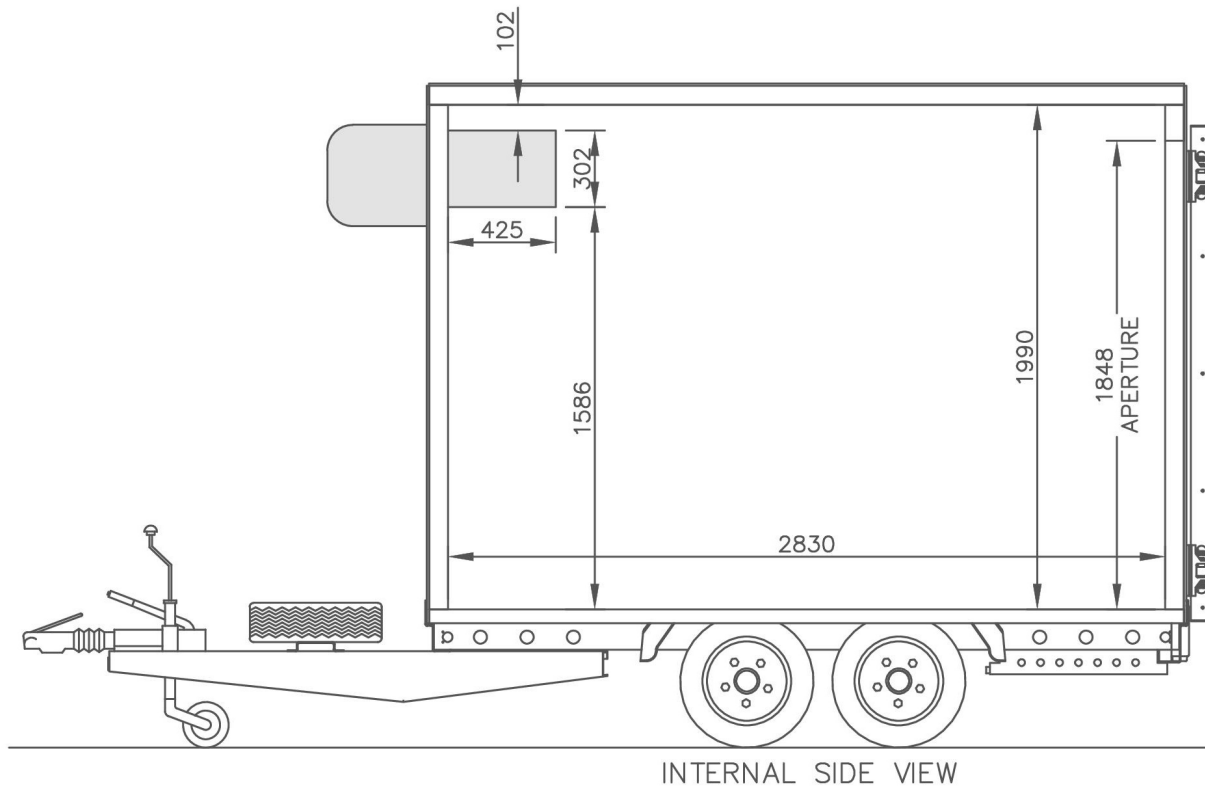

Panel dimensions near side / off side - internal