



## Features

- 4034mm x 1830mm X 1980mm body
- Twin braked axles 3000kg maximum GLW
- 83mm insulated panels
- Insulated floor with non-slip surface
- Slide out step
- Pair of rear stabilising legs
- Govi Artic 2000P chiller with 16amp skt
- +10 to -20° temperature range
- 14.72 cu mt of storage space
- Pressure relief valve

# TOW MASTER

4.2mt Fridge Trailer

HF042





## Optional Extras

- Polypropylene shelving
- Wheel clamp

An Icebox Fridge trailer is ideal if you have a need for temporary, emergency or portable cold storage solutions. With a temperature range of +10 to -20° Icebox fridge trailers can be used as fridge or freezer.

All trailers have an automatic interior light and the chiller automatically switches itself on or off when the door is opened or closed.

There is a slide out step below the access door and a pair of rear drop legs to stabilise the trailer on site.

**TOW  
MASTER**

4.2mt Fridge Trailer  
**HF042**

4.2mt Fridge Trailer  
HF042

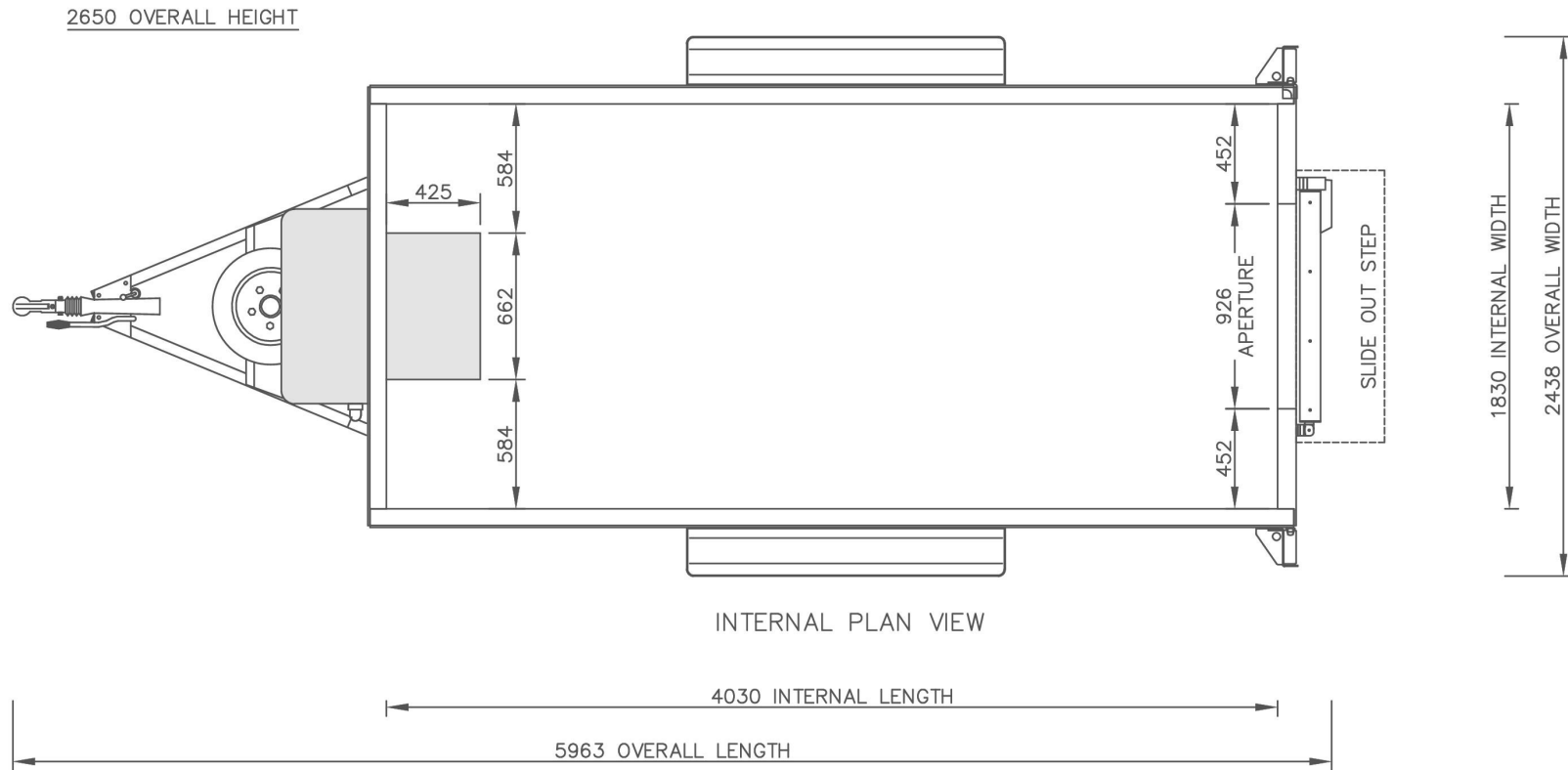

Plan view

4.2mt Fridge Trailer  
HF042

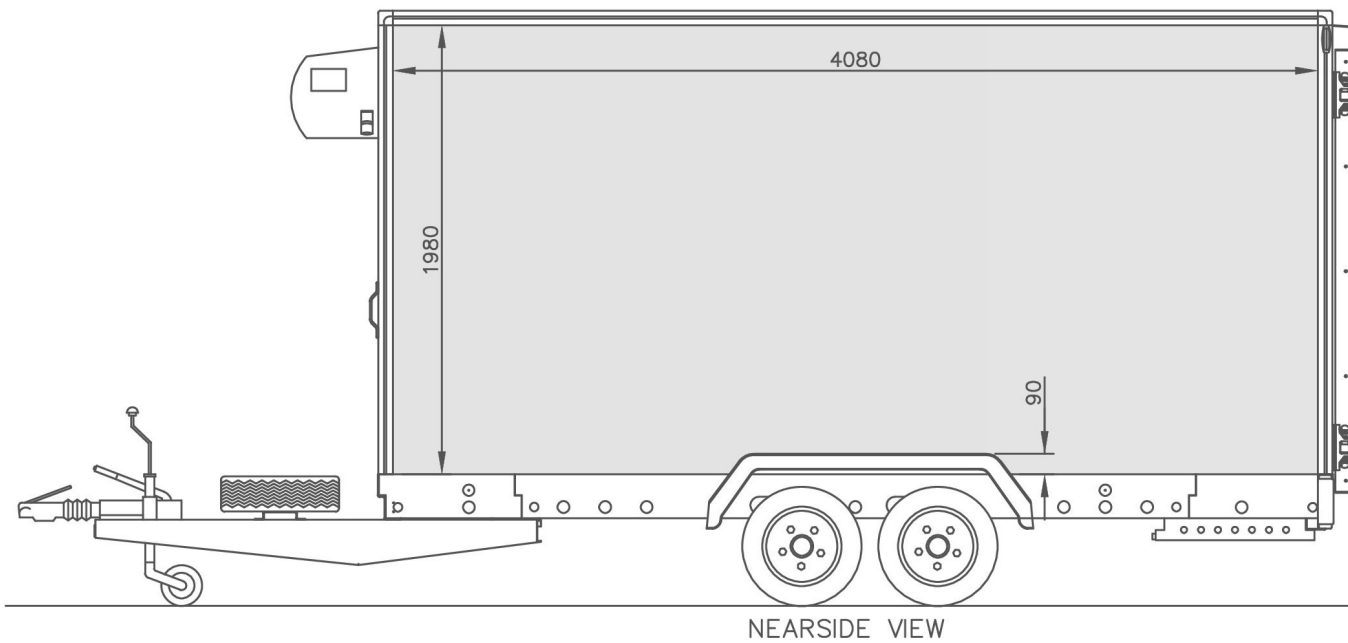

Panel dimensions near side / off side

4.2mt Fridge Trailer  
HF042

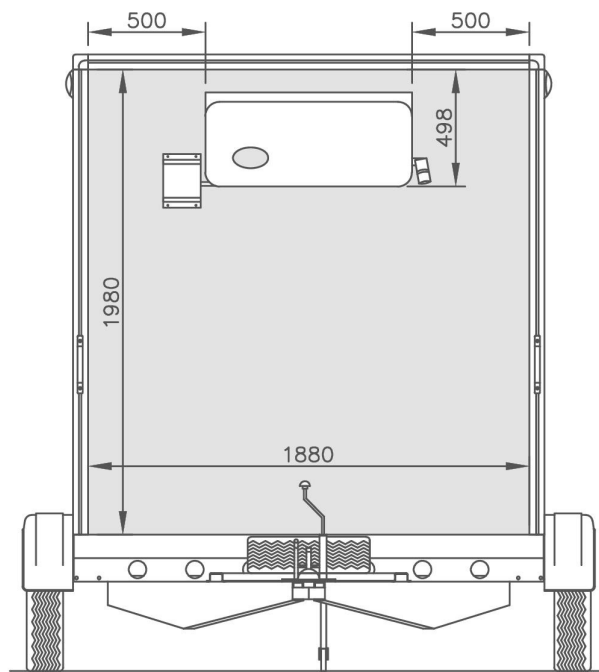

FRONT VIEW

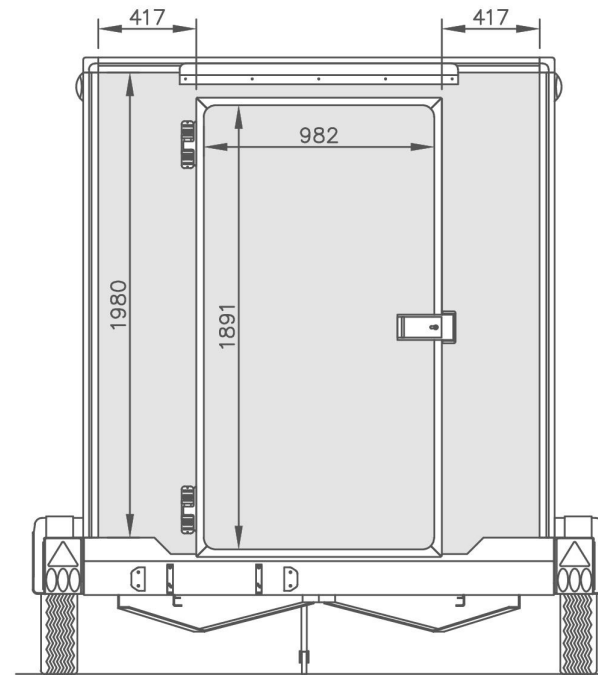

REAR VIEW

Panel dimensions front and rear

4.2mt Fridge Trailer  
HF042

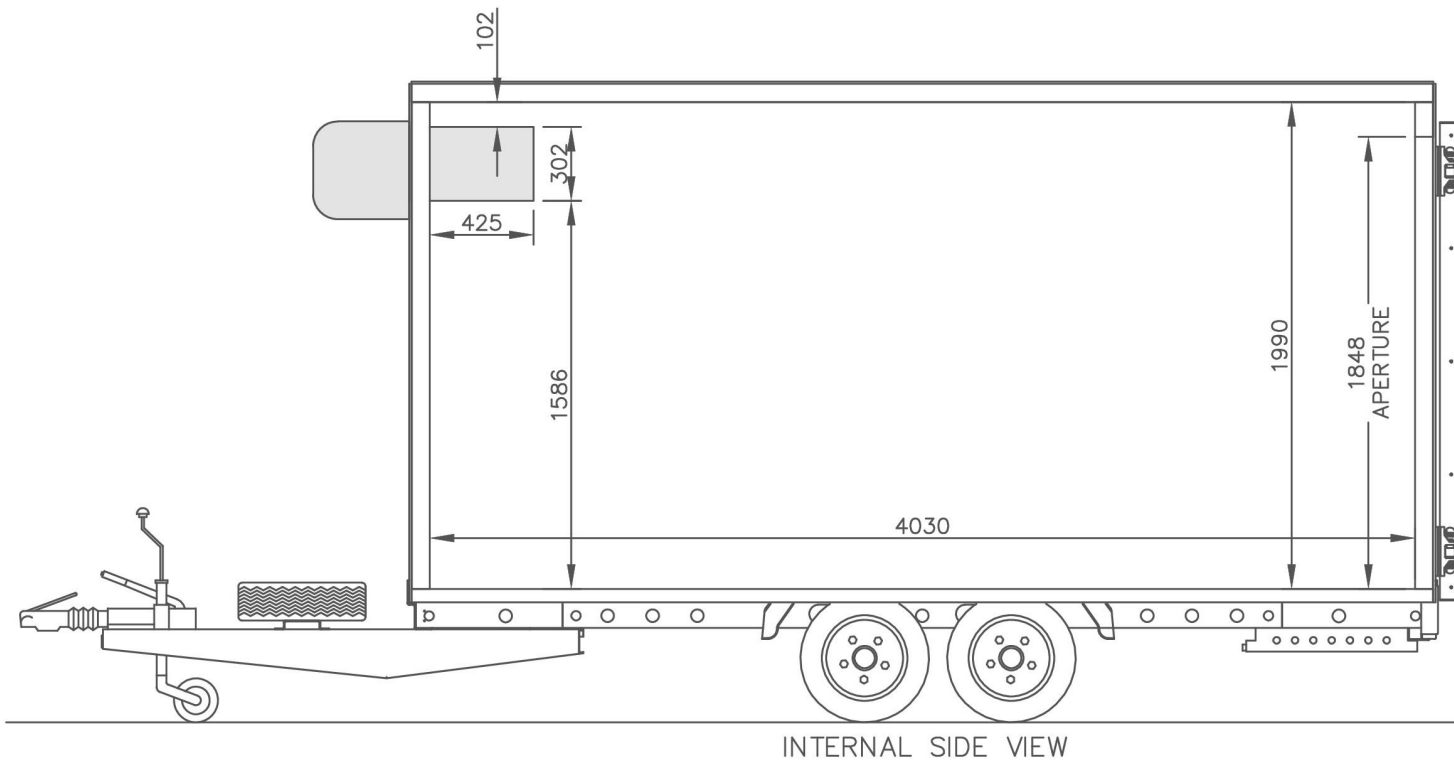

Panel dimensions near side / off side - internal