



## Features

- 69500mm x 2400mm X 2mm body
- Twin braked axles 3500kg maximum GLW
- Lift up canopy with logo board
- Pair of display wings
- Pedestrian door in rear end panel
- Pedestrian door step and handrail
- Non-slip vinyl floor covering
- 240v - 16amp - 2 double sockets, 6 low Profile LED strip lights

# TOW MASTER

7mt Merchandising Trailer

HM070





## Optional Extras

- Branded Display wing panel
- Branded logo board panel
- Vinyl wrapping
- Variety of slat wall shop fittings

A large trailer with room for plenty serving staff alongside lots of stock storage below counter height.

There is slat walling above the counter to the off side to which can be added a large variety of shop fittings to help display stock items.

A logo board and a pair of display wings allow for additional branding and a high visual impact to help make potential customers aware of your presence.

**TOW  
MASTER**

7mt Merchandising Trailer  
**HM070**



# 7mt Merchandising Trailer HM070



2700mm Overall Height (Closed)

2940mm Overall Height (Open)

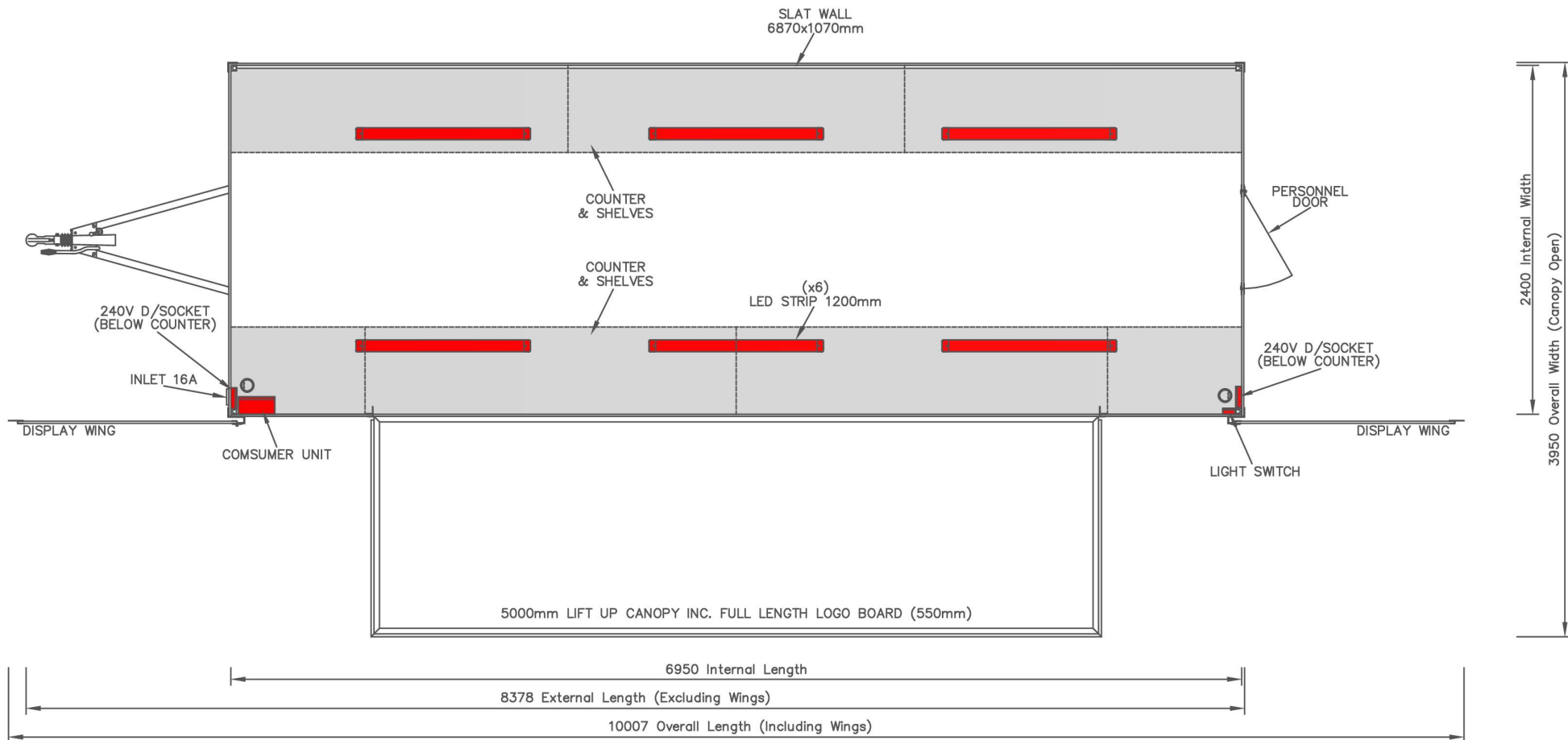

Plan view with lights and electrical sockets highlighted

7mt Merchandising Trailer  
HM070

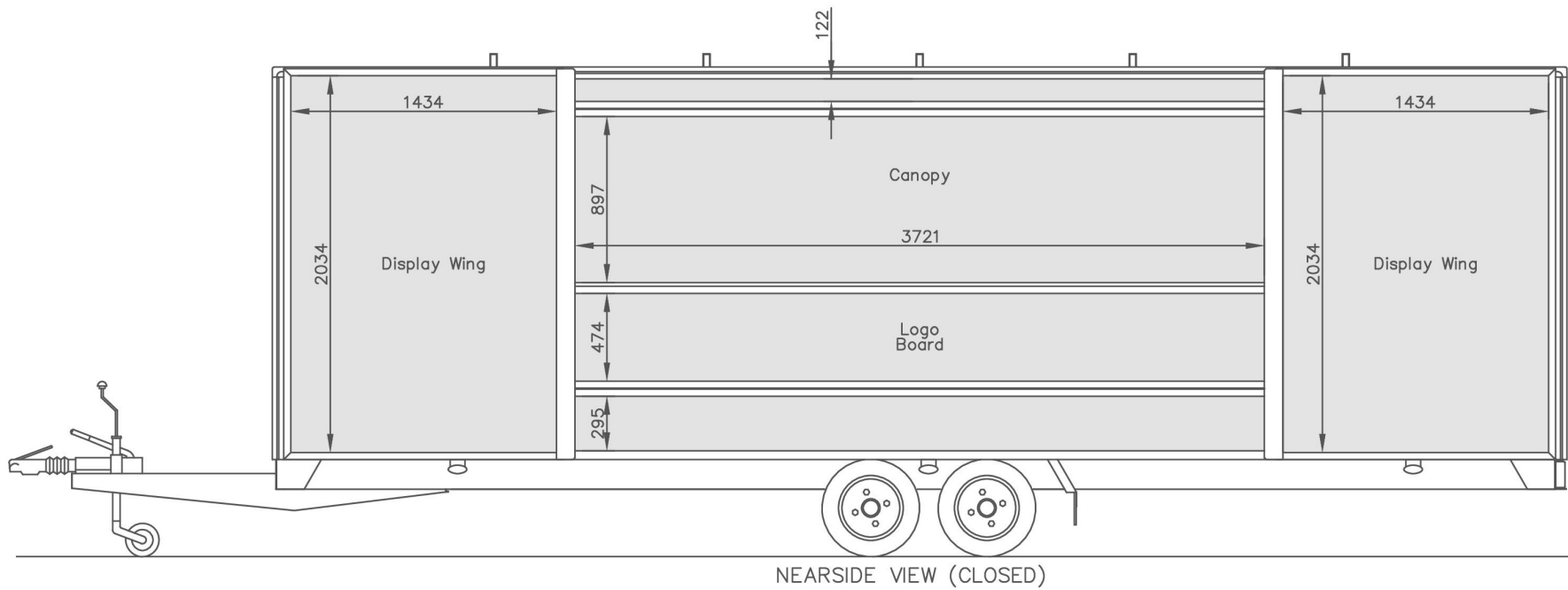

Panel dimensions near side closed

7mt Merchandising Trailer  
**HM070**

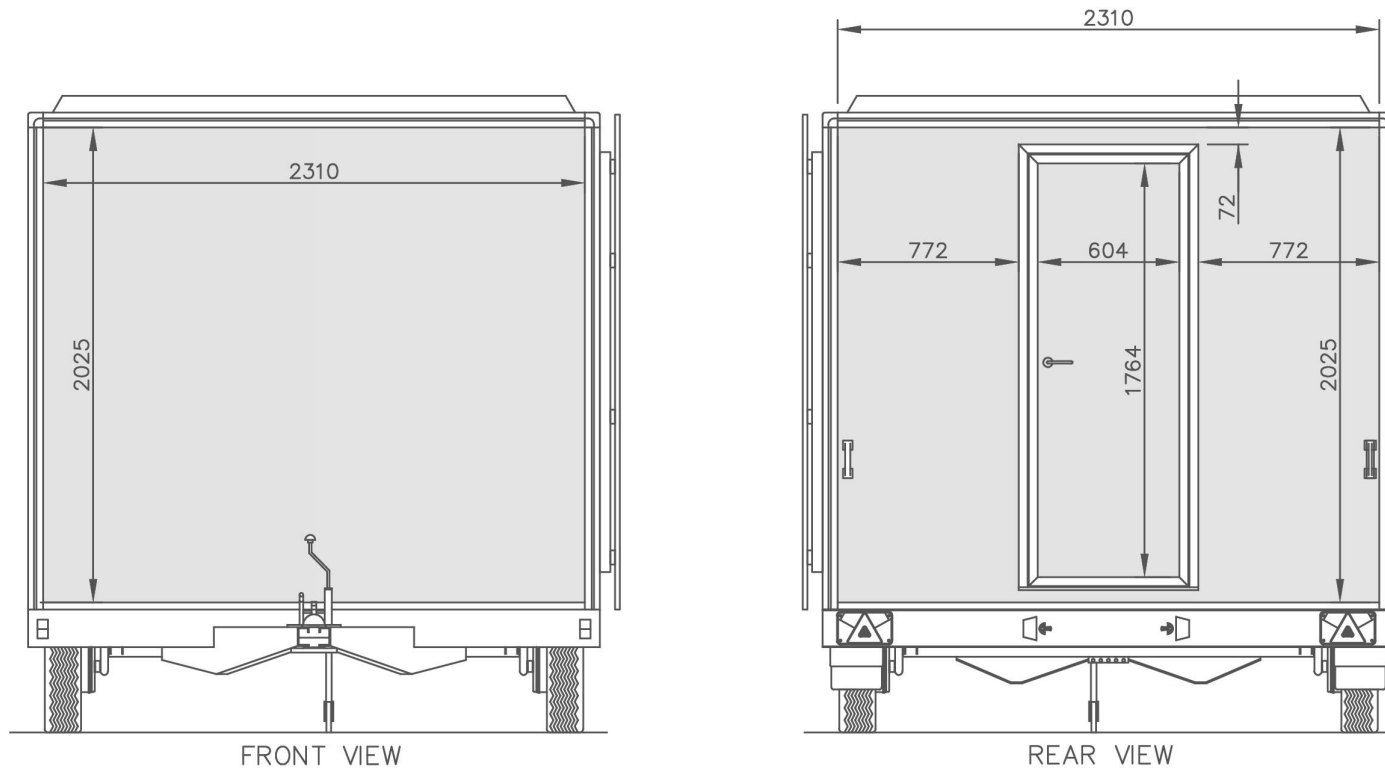

Panel dimensions front and rear

7mt Merchandising Trailer  
**HM070**

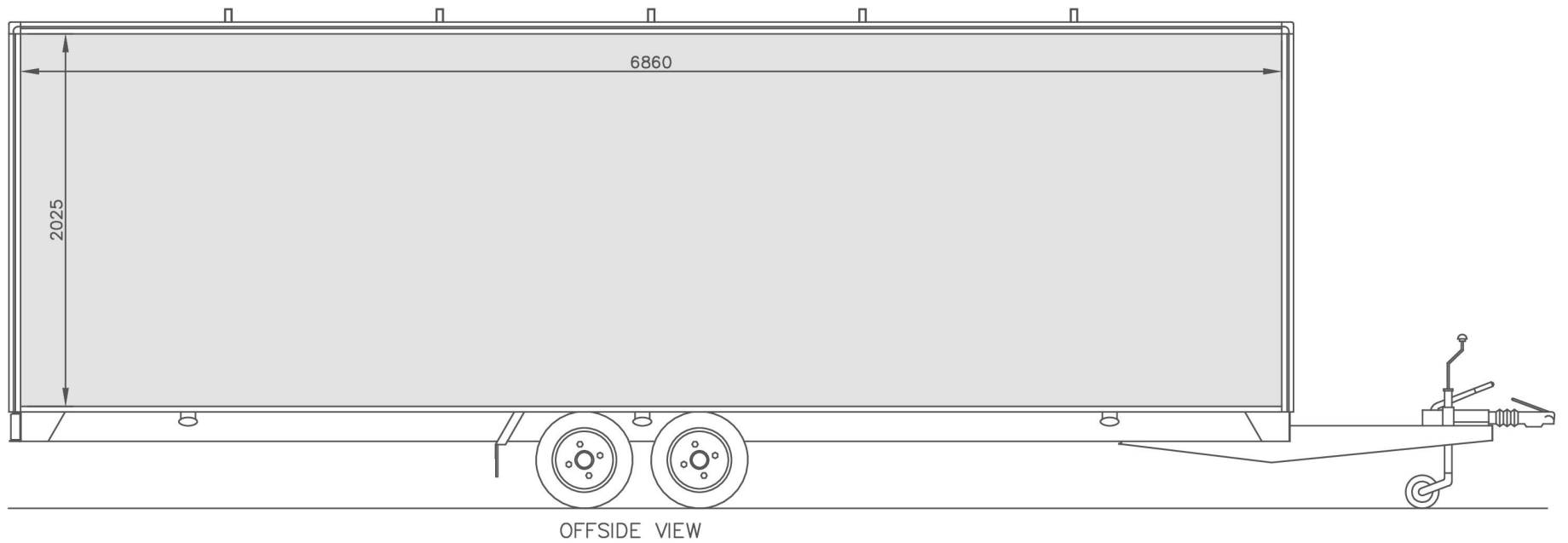

Panel dimensions off side closed

# 7mt Merchandising Trailer HM070



3mm ACP (Aluminium Composite Panel) Is Recommended For Slide In Graphic Panels

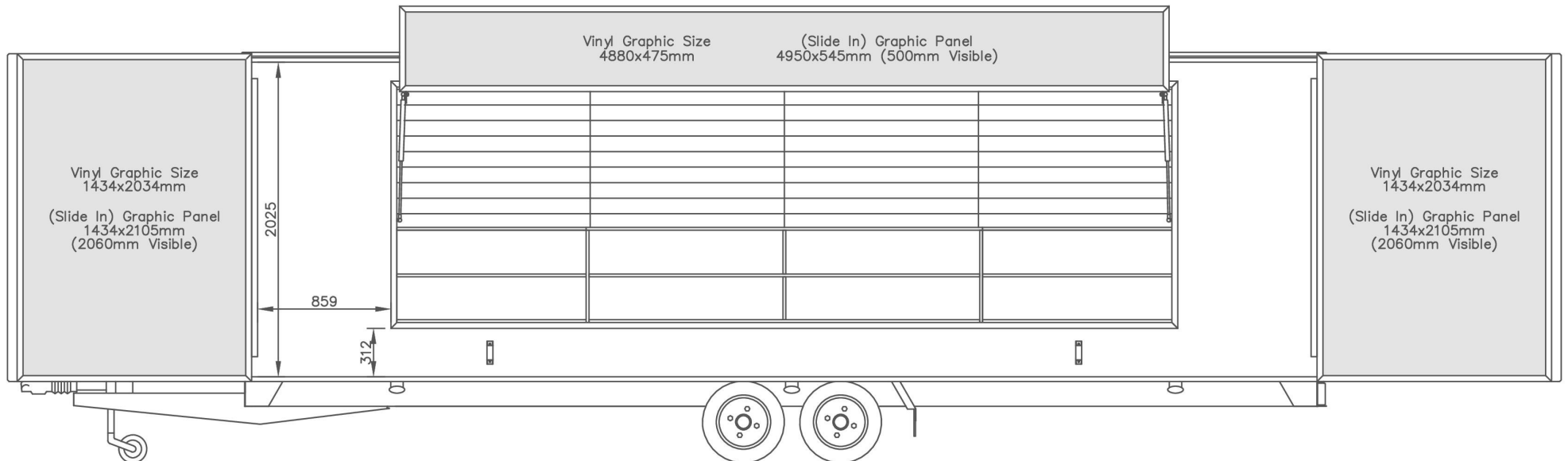

NEAR SIDE VIEW (OPEN)

Panel dimensions logo board and display wings